



**Sun  
Shading  
Expo**

NORTH AMERICA

**SEPTEMBER 24 – 26, 2024**

Anaheim Convention Center, Anaheim (CA)

## **Rules & Regulations**

# CONTENT

<b>I. BOOTH DISPLAY REGULATIONS</b>	<b>2</b>
<b>A. Standard and Corner Booth</b>	<b>10</b>
<b>B. Perimeter Wall Booth</b>	<b>11</b>
<b>C. Peninsula Booth</b>	<b>12</b>
<b>D. Island Booth</b>	<b>13</b>
<b>E. Canopies and Ceilings</b>	<b>14</b>
<b>F. Towers</b>	<b>15</b>
<b>G. Hanging Signs</b>	<b>16</b>
<b>II. EXHIBITOR APPOINTED CONTRACTOR AUTHORIZATION</b>	<b>17</b>

# Rules and Regulations

Exhibitors are responsible for ensuring their company, personnel, and booth are compliant with all event and local rules and regulations.

## EARLY DISMANTLE POLICY

No early dismantling of booths prior to the close of the show on **Thursday, September 26 at 1:00 pm.**

**NOTE:** Sun Shading Expo North America exhibit policies do not permit early dismantling without prior approval from Show Management. Violations are subject to a \$500 fine, and subject to additional penalties as stated in the Rules and Regulations, Item 17. For the safety of all Sun Shading Expo North America participants and integrity of the show, tear down of exhibits may not begin until show close.

In addition to Show Management regulations, exhibitors must also comply with all local rules and regulations.

## 1. CONTRACT FOR SPACE

The exhibit space contract properly executed by Applicant (Exhibitor) is subject to formal notice of acceptance by Show Management, Messe Stuttgart Inc. and is subject to all conditions, terms and regulations set forth herein and in the complete Sun Shading Expo North America 2024 Rules and Regulations (available on request). Messe Stuttgart Inc. reserves the right to reject any application or relocate exhibit space without assigning any cause therefore. The Exhibitor will assume the cost of any additional services/equipment required for their respective exhibit space.

Exhibitor shall not assign, sublet, share or apportion the whole or any part of the space allotted, or have representatives, products, equipment, signs or printed materials from other than its own firm contracted in the assigned exhibit space without the prior written consent of Show Management.

**Co-Exhibitors:** Fees apply. Contact Sales Manager for complete details.

**Additional Show Directory Listing:** Fees apply. Contact Sales Manager for complete details.

## 2. PAYMENT FOR SPACE

- a. Exhibit space must be reserved with full payment or a 25% nonrefundable deposit (U.S. Funds). Exhibitors must pay remaining 75% balance by March 1, 2024. After March 1, 2024, full payment is required to reserve exhibit space.
- b. To be eligible for the Advanced Textiles Association (formerly known as IFAI) member rate, the exhibitor must be a member of ATA (formerly known as IFAI) in good standing from the contract date through the duration of the 2024 show. Should the exhibitor's membership lapse, the non-member rate will apply and be due prior to the installation dates as stated in the full Messe Stuttgart Inc. Rules and Regulations.
- c. A \$100 per month late fee will be applied to any balance not paid by March 1, 2024. All past due monies owed Messe Stuttgart Inc. for any previous business transaction

must be paid in full prior to being allowed on the show floor. In the event that Messe Stuttgart Inc. cancels a booth due to outstanding balances, Messe Stuttgart Inc. may apply booth money to those outstanding invoices.

**NOTE:** Payments made by wire transfers must include an additional \$25 for domestic or \$45 for international. Any past-due invoices (e.g., advertisements, material sales, etc.) that the exhibitor owes Show Management must be paid three weeks before attending the exposition or the booth space and any payment received for the booth space may be forfeited. Show Management may apply forfeited booth money to outstanding invoices at its discretion.

### 3. CANCELLATION AND REDUCTION CHARGES

In the event of a cancellation or reduction of space by an exhibitor, an assessment to cover service performed and other damages relating to the action shall be made as follows:

#### REDUCTION OF SPACE

Before March 1: 20% of exhibit space rate difference

After March 1: 50% of exhibit space rate difference

#### CANCELLATION OF SPACE DURING THE PERIOD OF

Before March 1: 25% of space rate

March 1-May 31: 50% of the space rate

June 1-July 15: 75% of the space rate

After July 15: 100% of the space rate

It is understood that Messe Stuttgart Inc. reserves the right, at its option, to reassign cancelled booths regardless of the cancellation rate assessed. Subsequent reassignment of cancelled space does not relieve the canceling Exhibitor of obligation to pay the amount referred to above.

### 5. PROVIDED BY SHOW MANAGEMENT

All booths, except island booths, will have 8' (2.44m) high back drape and, 3' (.91m) high side dividers. Booths 300 sq ft or less will receive a 7"x 44" identification sign. Booths larger than 300 sq ft may receive a 7" x 44" identification sign upon request. All exhibitors are eligible to submit a company and product listing in the shared Expo Guide, mobile app, and online show floor map of Sun Shading Expo / Advanced Textiles Expo. Exhibitors will be provided with a no-cost VIP Discount that they can distribute to unlimited customers, contacts, and colleagues outside of the exhibiting company.

**COLORS** - The drape color will be blue.

### 6. INSTALLATION AND DISMANTLING

There will be no exceptions to the installation or dismantling hours unless prior written approval is received by Show Management. Installation and dismantling will be done by the exhibitor or its agent at the expense of the exhibitor.

**NOTE:** No person under the age of 18 is allowed on the show floor during installation and dismantling hours.

## INSTALLATION

Any space not claimed and occupied three hours prior to the opening hour of the exhibit may be reassigned without refund.

Sunday, September 22 | 8:00 am–5:00 pm  
Monday, September 23 | 8:00 am–5:00 pm

## DISMANTLING

The exhibitor expressly agrees not to dismantle its exhibit or do any packing before the final closing of the trade show. Any display not claimed will be dismantled and stored by the exhibit service company at the expense of the exhibitor.

Thursday, September 26 | 1:00–8:00 pm  
Friday, September 27 | 8:00 am–Noon

**NOTE:** Sun Shading Expo North America exhibit policies do not permit early dismantling without prior approval from Show Management. Violations are subject to a \$500 fine, and subject to additional penalties as stated in the Rules and Regulations, Item 17. For the safety of all Sun Shading Expo North America participants and integrity of the show, tear down of exhibits may not begin until show close.

## 7. BOOTH DESIGN

Booths are required to have carpeting or floor covering. All exposed parts of the display must be finished so as not to be objectionable or obstruct other exhibits, and the outside facing must be neutral.

**NOTE:** See specific booth design restrictions in the Booth Display Regulations section of Exhibitor Service Manual.

## 8. RESTRICTIONS AND LIMITATIONS

A. **MATERIAL HANDLING** - Exhibitors and full-time employees of exhibiting companies may unload their own vehicles provided their privately owned vehicle (POV) qualifies and they do not use any material handling equipment. A POV is considered to be any vehicle that is primarily designed to transport passengers, not cargo or freight. Vehicles must not be left unattended at the loading areas. Any unattended vehicles will be towed at owner's expense. Freeman has the responsibility of receiving and handling all exhibit materials and empty crates. It is their responsibility to manage docks and schedule vehicles for the smooth and efficient move-in and move-out of the exhibition. Freeman will not be responsible, however, for any material they do not handle. Freeman will have complete control of the loading docks at all times. Please see the Freeman and facility sections of this service manual for more details.

B. **AUDIO VISUALS** - Exhibits which include the operation of musical instruments, radios, public address systems, slide or motion picture projection or any noise-making machines must be conducted or arranged so that the noise resulting from the demonstration will not annoy or disturb adjacent exhibitors and their patrons. Operators of noise-making exhibits must secure approval from Show Management of operating methods before exhibit opens. Exhibitor is responsible for attaining appropriate music licensing through

[www.bmi.com/licensing](http://www.bmi.com/licensing) or [www.ascap.com/music-users](http://www.ascap.com/music-users) if playing music at their booth in any manner. Proof of licensing must be made available upon request.

C. **SOUND LEVEL** - Any noise generated by operating equipment, booth displays, or machinery must not exceed 80 dB when measured from a distance of 10 ft (3.05m), or be determined obtrusive by show management.

D. **SOLICITATIONS** - No solicitations shall be permitted outside of the exhibitor's assigned space, and no signs or placards may be displayed on persons or otherwise outside exhibit space. This rule applies to all participants of Sun Shading Expo North America, unless it is a Show Management approved item. Any signs or collateral found outside the assigned exhibit space may be automatically discarded without notice.

E. **CHARACTER OF EXHIBITS** - Show Management reserves the right to restrict, prohibit or evict any portion of an exhibit without assigning any cause therefore. This reservation covers persons, things, conducts, printed matter or anything of a character which Show Management determines should be restricted, prohibited or evicted. In the event of such restriction, prohibition or eviction, Show Management is not liable for any refunds or rentals or other exhibit expenses.

F. **DEMONSTRATIONS** - If you expect many attendees to congregate in one area at one time, you must leave space within your own exhibit area to absorb the majority of the crowd.

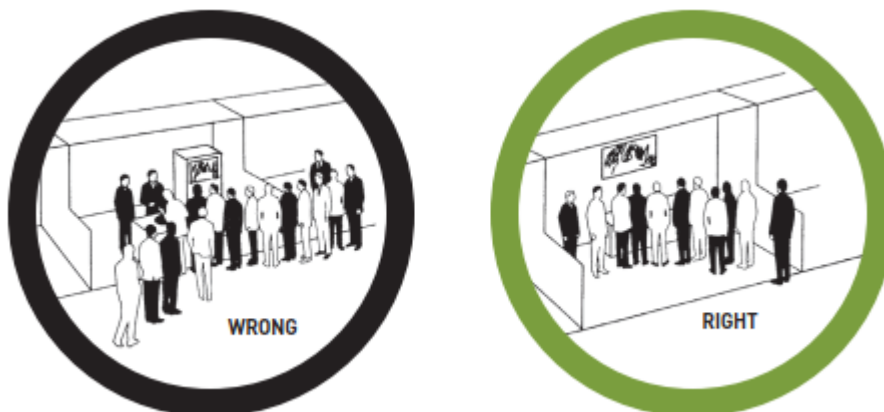

**Intent:** The aisles are to service all exhibitors; therefore, each exhibitor has the responsibility to assure proper flow of traffic through the entire exposition. When large crowds gather to watch a demonstration or entertainment and interfere with the flow of traffic down aisles, or create excessive crowds in neighboring booths, this is an infringement on the other exhibitors' rights. Aisles must not be obstructed at any time.

G. **COMPLIANCE** - The Exhibitor assumes all responsibility for any compliance with all pertinent ordinances, regulations and codes of duly authorized local, state and federal governing bodies concerning fire, safety and health, together with the rules and regulations of the operators and/or owners of the property wherein the show is held.

#### **AMERICANS WITH DISABILITIES ACT (ADA)**

Exhibitors are responsible for ensuring their displays are in compliance with the Americans with Disabilities Act (ADA). Examples include, but are not limited to: ensuring an equal attendee experience is offered on all levels of a multi-story booth, exhibits being wheelchair accessible, displays are arranged at an appropriate height to accommodate a person sitting in a wheelchair. All companies are to accommodate reasonably to attendees with disabilities. Additional information is available at [www.ada.gov](http://www.ada.gov).

H. **LIVESTOCK** - No live animals will be allowed in the exhibits. This rule applies to all participants of the Sun Shading Expo North America.

I. **BALLOONS** - No helium balloons will be allowed in the exhibits. This rule applies to all participants of the Sun Shading Expo North America.

J. **FOOD AND BEVERAGE** - All food and beverage must be provided by the exclusive provider. Please see the Catering section of this Service Manual for more details.

K. **REFUSE** - Any exhibitor that distributes or produces any type of item, such as popcorn, that produces debris in the aisle or other exhibitors booths, will be responsible for the cost of hiring porters to keep the show floor clean during show hours.

L. **GENERATORS/AIR COMPRESSORS** - Portable generators or air compressors are subject to local ordinance and center regulations.

M. **CAMERAS** - The taking of pictures by an exhibiting company's personnel of another exhibitor's products could result in the expulsion of the offending company from future Show Management sponsored expositions. This rule is applicable for all Show Management functions and applies to all event participants. Noncompliance will result in the confiscation of all images/film, immediate deletion of all images on an electronic device, and possible removal from the show floor. Sun Shading Expo North America's official exposition photographer maintains rights to all professional images.

N. **VEHICLES** - The use of vehicles for display of any type must be pre-approved by Show Management and must meet local fire and safety requirements.

O. **STORAGE OF MATERIALS** - Fire codes restrict the storage of any type of materials behind the exhibitor's booth. Items needed by the exhibitor for packing should have empty stickers placed on them so they can be stored and returned at the close of the show.

P. **LUGGAGE** - No luggage will be allowed on the show floor. This rule applies to all participants at Sun Shading Expo North America.

Q. **CONVENTION CENTER RULES** - It is each exhibitor's responsibility to ensure they are in compliance with convention center rules and regulations.

<https://visitanaheim.mediavalet.com/portals/ACC-Rates-Policies-Guidelines>

## 9. LIABILITY

The Exhibitor agrees that Messe Stuttgart Inc. shall not be liable for any damage to exhibit or material during shipping or delivery to booth or damage or liability of any kind, including content of display or literature, or for any damage or injury to person or property during the term of this agreement, from any cause whatsoever by reason of use, occupation and enjoyment of exhibit space by the Exhibitor or any person thereon with the consent of the Exhibitor, and that the Exhibitor will indemnify and hold harmless Messe Stuttgart Inc. from all liability whatsoever, including all litigation expenses, court costs and attorney fees, on account of any such damage, or injury, whether or not caused by negligence or of breach an obligation by the Exhibitor or its employees or representatives.

A. **INSURANCE** - The exhibitor is responsible for providing sufficient insurance protection. As a standard requirement for Sun Shading Expo North America, it will be necessary for the exhibitor to carry general liability coverage from an insurance company in good standing with minimum policy limits of \$1,000,000 per occurrence and \$2,000,000 aggregate.

Exhibitors must provide a certificate of liability insurance with Messe Stuttgart Inc., Freeman, and the convention center listed as an additional insured. As Sun Shading Expo North America's official insurance vendor, Rainprotection Insurance will be contacting exhibitors directly to collect and record compliant insurance certificates.

The primary contact for the exhibiting organization's information (name, title, email address, mailing address, country, and phone number) will be shared with Rainprotection Insurance for the sole purpose of collecting insurance certification, verifying adequate coverage, and providing an opportunity for the exhibitors to purchase coverage for this event only. To review Rainprotection's privacy policy, please visit <https://www.rainprotection.net/>.

## **10. LOSS OR DAMAGE**

Show Management, its officers and staff members will not be responsible for the safety of the property of the exhibitors from theft, damage by fire, accident, or other causes, but will use reasonable care to protect the exhibitors from such loss and will have security personnel on duty. No responsibility is assumed for goods delivered to the exhibit area before setup day or for unpacked materials left in the exhibit area after the closing hour of the exhibit. Exhibitors wishing to insure their goods must do so at their own expense. This rule applies to all participants in the Sun Shading Expo North America.

## **11. MEETINGS, PRIVATE PARTIES AND TOURS**

Hospitality suites, special events, meetings and tours must be approved by Show Management and may not compete/overlap with any scheduled Sun Shading Expo North America or Advanced Textiles Expo events. Further, hosted parties and tours at which attendance is restricted to either verbal or written invitation are not permitted during any official Sun Shading Expo North America or Advanced Textiles Expo activity. Meeting rooms and suites will not be released to non-exhibiting suppliers at the convention facility and/or hotels within the Sun Shading Expo North America or Sun Shading Expo hotel block.

## **12. PUBLIC ADDRESS SYSTEM**

The Public Address (PA) System in the exhibit hall will be used only to announce the opening and closing of the show and matters of public safety. Other announcements will be at the discretion of Show Management.

## **13. EXHIBIT HALL INSPECTION**

Show Management will conduct an exhibit hall inspection during exhibitor installation days at which time any violations will be noted and the exhibiting company will be required to correct said violation(s) prior to show opening. Refusal or failure may result in Show Management correcting said violation(s) at the exhibitor's expense, or possible eviction from the trade show. If you have any questions, please feel free to contact Show Management.

## **14. ENTERING ANOTHER EXHIBITOR'S BOOTH**

No exhibit personnel of one company will enter another company's booth that is not staffed by employees of the other exhibiting company. This rule applies throughout Sun Shading Expo North America.



## **15. NON-EXHIBITOR SOLICITATION**

Suitcasing, which is soliciting business at the exposition by non-exhibiting personnel, is strictly forbidden. Any non-exhibiting attendee who is observed to be soliciting business as a supplier will be in violation of Show Management's anti-suitcasing policy and will be asked to leave immediately and subject to additional penalties at the discretion of Show Management. Please report any suspected suitcasers to Sun Shading Expo North America Show Management.

## **16. COMPLIANCE**

The Exhibitor assumes all responsibility for any compliance with all pertinent ordinances, regulations and codes of duly authorized local, state and federal governing bodies concerning fire, safety and health, together with the rules and regulations of the operators and/or owners of the property wherein the show is held.

## **17. PENALTIES**

Any exhibitor or registrant that does not comply with the Sun Shading Expo North America Rules and Regulations as stated herein is subject, at the discretion of Messe Stuttgart Inc. and based on the severity of the infraction, including but not limited to any or all of the following: loss of booth selection priority points, immediate expulsion from the event, loss of Advanced Textiles Association (formerly known as IFAI) membership, ban from exhibiting or registering at future Messe Stuttgart Inc. sponsored events, confiscation of cameras and/or film, and monetary fines.

## **18. FORCE MAJEURE**

Messe Stuttgart Inc. reserves the right to change the location or cancel expositions in the event a strike, fire, war, government regulation, disaster, civil disorder, curtailment of transportation facilities, pandemic, or Act of God should render the hall in which the convention has been scheduled unusable. No refunds of exhibit space payments will be distributed until Messe Stuttgart Inc. has officially declared in writing that Sun Shading Expo North America 2024 has been cancelled. If Sun Shading Expo North America is cancelled and rescheduled, Exhibitor agrees that it will make its best effort to continue to participate on the rescheduled dates.

## **19. SPONSORSHIPS**

Sun Shading Expo North America sponsorships will be offered exclusively to and purchased by contracted exhibiting companies at Sun Shading Expo North America 2024, except at the discretion of Show Management.

## **20. COMPLIMENTARY DISPLAY SPACE**

Show Management has the right to assign complimentary display space to organizations or companies within the exhibit hall or common areas of the annual exposition. Booth furnishings, power, shipping and materials handling will be the responsibility of the exhibitor unless specified in writing by Show Management.

## Booth Display Regulations

Exhibitors are responsible for ensuring their booth display complies with all exhibit dimension regulations. Show management will conduct an exhibit hall inspection during installation at which time any violations will be noted and the exhibiting company will be required to correct said violation(s) prior to show opening. Refusal or failure may result in penalties as stated in Item 17 in the Rules and Regulations section of the Exhibitor Service Manual.

Booth Display Regulations are designed to adhere to standard exhibit industry practices as defined in the International Association of Exhibits and Events (IAEE) Guidelines for Display Rules and Regulations.

NOTE: Exhibitors are responsible for ensuring they are in accordance of all rules and regulations.

All references to "Show Management" refers to Messe Stuttgart Inc. show management team.

Booth Type	Description	Max Height	Sightline Regulations	Hanging signs permitted?
Standard/ In-line	Standard, or "in-line", booths are exhibit spaces with booths on both sides and behind. This type of booth only has one exhibit side open to an aisle.	Front half of booth: 4' Back half of booth: 8'	All display fixtures over 4' in height must be confined to area within 5' of the back line.	No
Corner	Corner booths are in-line booths with exposure to aisles on two sides.	Front half of booth: 4' Back half of booth: 8'	All display fixtures over 4' in height must be confined to area within 5' of the back line.	No
Perimeter	Perimeter booths are exhibit spaces located on the outer-perimeter wall of the exhibit floor.	Front half of booth: 4' Back half of booth: 12' *unless otherwise limited by center	All display fixtures over 4' in height must be confined to area within 5' of the back line.	Yes
Peninsula	Peninsula booths are exhibit spaces with two or more units with aisles on three sides.	Sides of booth: 4' Center of booth: 8'	All display fixtures over 4' in height must be confined to area within 5' of the center line to avoid blocking the sightline from the aisle to the adjoining booths.	No
Island	Island booths are exhibit spaces with aisles on four sides.	<i>All booth components: 20'</i>	The entire cubic content of the space may be used up to the maximum allowable height.	Yes

## A. Standard and Corner Booth

Exhibit in one or more units in a straight line.

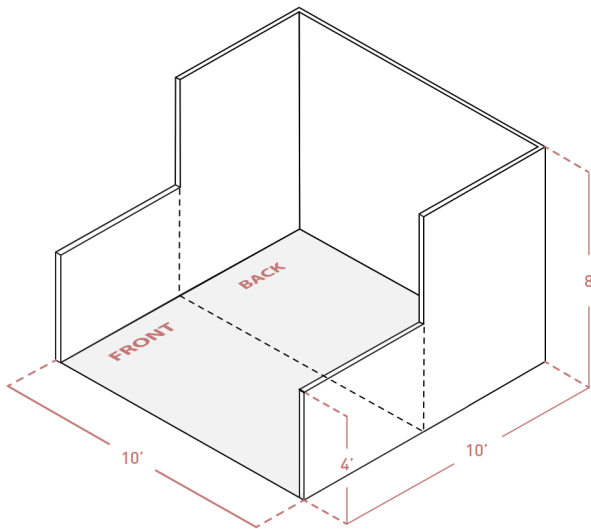

- A Front half fixtures max height 4'
- B Back half fixtures max height 8'

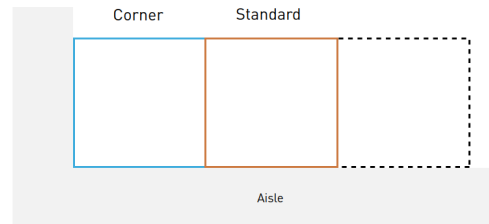

### Height

Exhibit fixtures, components and identification signs will be permitted to a maximum height of 12' (3.65m) in perimeter-wall booths, unless otherwise limited by the convention center.

**Intent:** If a portion of an exhibit booth extends above 8' (2.44m) high, the exhibit booth background will detract from the overall impact of the exhibit directly behind that booth regardless of how the rear of the offending exhibit is finished.

### Depth

All display fixtures over 4' (1.22m) in height and placed within 10 lineal feet (3.05m) of an adjoining exhibit must be confined to that area of the exhibitor's space which is within 5' (1.52m) of the back line.

**Intent:** Each exhibitor is entitled to a reasonable sight line from the aisle regardless of the size of exhibit. Exhibitors with larger space—30 lineal feet (9.14m) or more—should also be able to effectively use as much of the total floor space as possible as long as they do not interfere with the rights of others. The limitation on display fixtures over 4' (1.22m) and within 10 lineal feet (3.05m) of a neighboring exhibit is intended to accomplish both of these goals.

### IMPORTANT

Space dimensions shown on floor plan are from center line of booth equipment, such as side rails and/or back drape. Exhibit structures must be constructed to allow sufficient tolerance on each side for this equipment and for utility service at rear of booth.

## B. Perimeter Wall Booth

Exhibit in units located on the outer-perimeter wall of the exhibit floor.

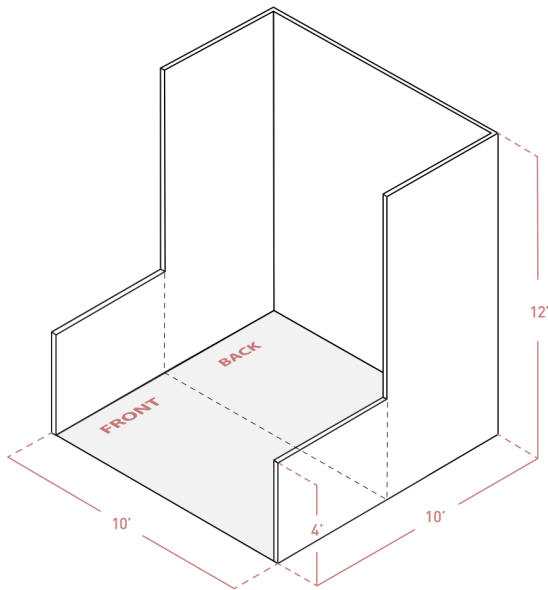

- A Front half fixtures max height 4'
- B Back half fixtures max height 12'

### Height

Exhibit fixtures, components and identification signs will be permitted to a maximum height of 12' (3.65m) in perimeter-wall booths, unless otherwise limited by the convention center.

**Intent:** Because the outer perimeter booths are not backed up against another exhibitor's booth, display back walls and materials over 8' (2.44m) will not interfere with or distract from any other exhibit booth.

### Depth

All display fixtures over 4' (1.22m) in height and place within 10 lineal feet (3.05m) of an adjoining exhibit must be confined to that area of the exhibitor's space which is within 5' (1.52m) of the back line.

**Intent:** Each exhibitor is entitled to a reasonable sightline from the aisle regardless of the size of exhibit. Exhibitors with larger space—30 lineal feet (9.14m) or more—also should be able to effectively use as much of the total floor space as possible, as long as they do not interfere with the rights of others. The limitation on display fixtures over 4' (1.22m) and within 10 lineal feet (3.05m) of a neighboring exhibit is intended to accomplish both of these goals.

**NOTE:** We suggest that exhibitors considering a perimeter-wall booth in order to take advantage of the extra height permitted should design their exhibit so it can be used at the 8' (2.44m) height and the 12' (3.65m) height so it can be used in all future shows, even if a perimeter-wall space is not available.

### IMPORTANT

Space dimensions shown on floor plan are from center line of booth equipment, such as side rails and/or back drape. Exhibit structures must be constructed to allow sufficient tolerance on each side for this equipment and for utility service at rear of booth.

## C. Peninsula Booth

Exhibit in two or more units back-to-back with an aisle on three sides.

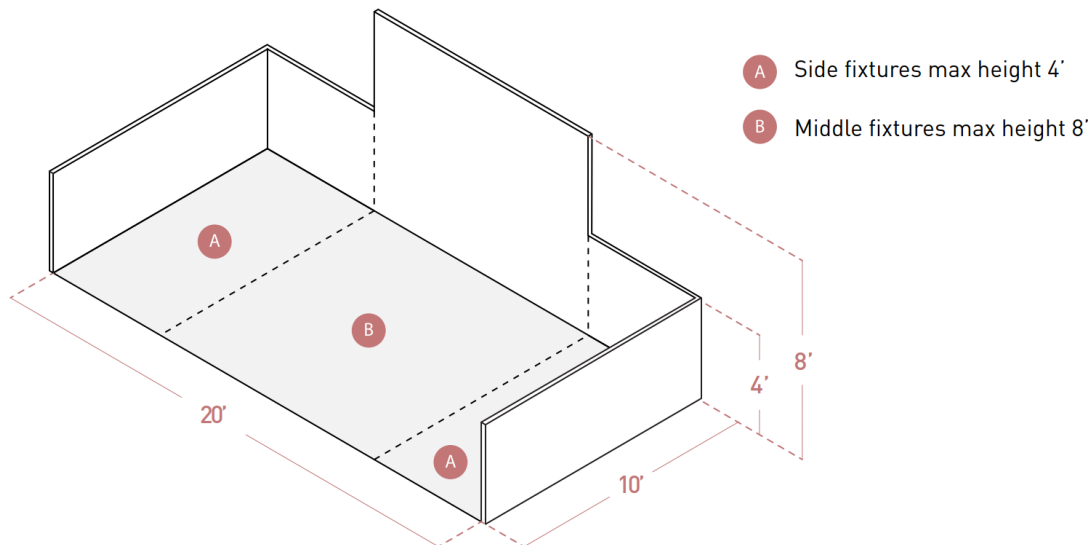

### Height

Exhibit fixtures, components and identification signs will be permitted to a maximum height of 8' (2.44m).

**Intent:** If a portion of an exhibit booth extends above 8' (2.44m) high, the exhibit booth background will detract from the overall impact of the exhibit directly behind that booth regardless of how the rear of the offending exhibit is finished.

### Depth (10' x 20' Booth)

All display fixtures over 4' (1.22m) in height and placed within 10 lineal feet (3.05m) of a neighboring exhibit must be confined to that area within 5' (1.52m) of the center line to avoid blocking the sightline from the aisle to the adjoining booths.

### Depth (20' x 20' Booth)

The 10' x 20' portion of a 20' x 20' booth that adjoins other booths must comply with the regulations set forth above for a 10' x 20' booth. The other 10' x 20' portion of the booth may have display fixtures to a maximum height of 8' (2.44m).

**Intent:** Exhibitor's adjoining peninsula exhibits are entitled to the same reasonable sight line from the aisle as they would expect if they were adjacent to an exhibit with a standard booth.

**NOTE:** Peninsula booths are normally "faced" toward the cross aisle. Any portion of the exhibit bordering another exhibitor's booth must have the back side of that portion finished and must not carry identification signs or other copy that would detract from the adjoining exhibit.

### IMPORTANT

Space dimensions shown on floor plan are from center line of booth equipment, such as side rails and/or back drape. Exhibit structures must be constructed to allow sufficient tolerance on each side for this equipment and for utility service at rear of booth.

# Island Booth

Exhibit exposed to aisles on all four sides.

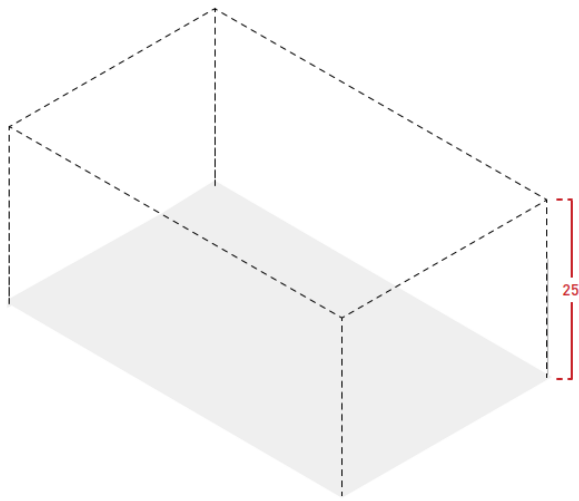

👁️ The entire cubic content of the space may be used up to the maximum allowable height.



## Height

Exhibit fixtures, components and identification signs will be permitted to a maximum height of 20' (6.096m) in island booths.

**Intent:** When an island booth exceeds 8' (2.44m), it does not interfere with other exhibitors because it obviously does not back up against another exhibitor's back wall. The extra height is often required in an island booth exhibit to permit the open walk-through approach normally used in this type of location.

## Depth

Because an island booth is automatically separated by the width of an aisle from all neighboring exhibits, full use of the floor plan is permitted.

## Side Walls

The entire cubic content of the space may be used up to the maximum allowable height.

## Structural Integrity

All multi-story exhibits, regardless of whether people will occupy the upper area or not, must provide drawings for inspection at least 60 days prior to the show by Show Management, the installation and dismantling contractor, the exhibitor and governmental authority during the time the exhibit is being erected, exhibited and dismantled at the show site. All such exhibits also must include a signature or stamp of a reviewing structural engineer indicating that the structure design is properly engineered for its proposed use, and a signature of an authorized official of the exhibit building company indicating that the structure is built in compliance with the details and specifications set forth on the drawings.

Signs also must be posted indicating the maximum number of people the structure will accommodate.

## Low Ceiling Areas

The maximum height in low ceiling areas is 15' and rigging is prohibited.

**Intent:** Exhibitors in the vicinity of island exhibits are entitled to the same reasonable safety precautions they would expect if they were adjacent to a standard booth.

**IMPORTANT** Exhibitors are cautioned when installing a display with a ceiling or second level to check with Show Management to insure that their display meets the necessary fire safety precautions involving smoke alarms, fire extinguishers, sprinkler systems, etc.

# Canopies and Ceilings

An exhibit that is covered in part or whole.

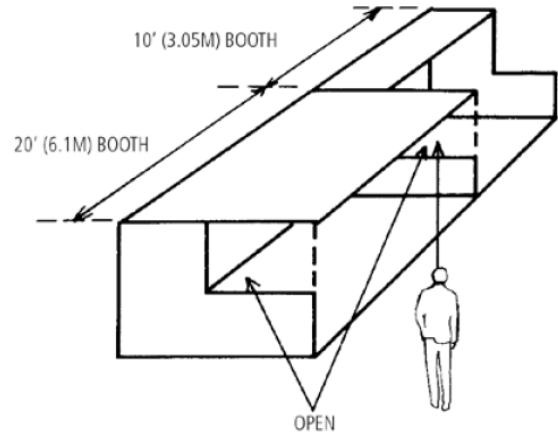
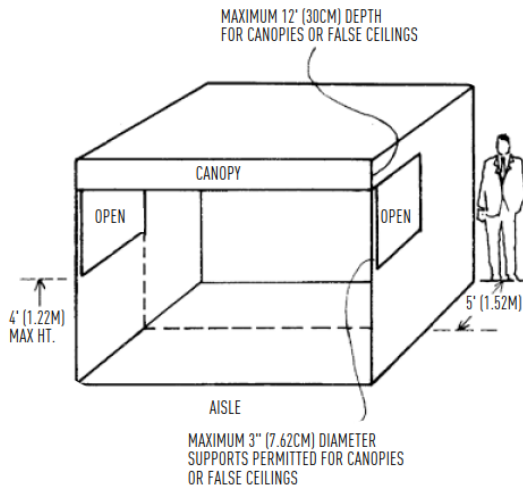

## Height

Canopies, false ceilings and umbrellas will be permitted to a height that corresponds to the height regulation for the appropriate exhibit configuration of which they are a part. For example, canopies will not exceed 8' (2.44m) in height in a standard booth configuration. Furthermore, the canopy or false ceiling will not exceed 1' (30cm) in depth.

**Intent:** Exhibitors requiring canopies or false ceilings to create the desired exhibit environment within their booth space should be allowed to do so as long as the canopy and its support structure do not violate the intent of the height or depth regulation.

## Depth

Canopies may extend out to the aisle line and up to the booth line on either side of an exhibitor's space, providing that the support structure will not exceed 3" (7.62cm) in width when placed within 10 lineal feet (3.05m) of an adjoining exhibit and not confined to that area of the exhibitor's space which is within 5' (1.52m) of the back line.

**Intent:** Exhibitors adjoining exhibits with canopies are entitled to the same reasonable sight line from the aisle as they would expect if they were adjacent to an exhibitor with a standard booth.

**IMPORTANT** Exhibitors are cautioned when installing a display with a ceiling or covered booth to check with Show Management to insure that their display meets the necessary fire safety precautions involving smoke alarms, fire extinguishers, sprinkler systems, etc.

# Towers

A free-standing exhibit component separate from the main exhibit fixture that is used for identification and display purposes only.

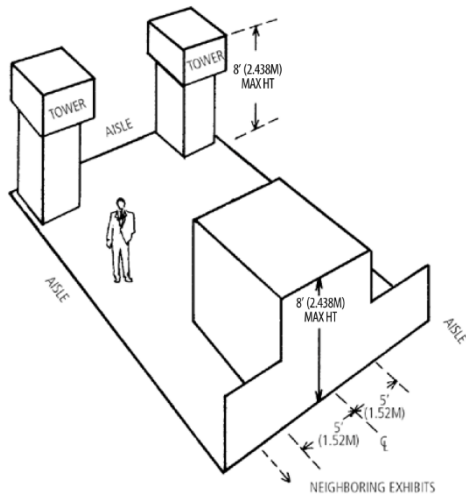

## Height / Depth

Towers will be permitted to a height and depth that correspond to the height and depth regulations for the appropriate exhibit configuration of which they are a part. For example, towers that are part of a peninsula exhibit consisting of two corners and two standard booths will not exceed 8' (2.44m) in height, and will not be placed within 10 lineal feet (3.05m) of a neighboring exhibit to avoid blocking the sight line from the aisle to the adjoining booth.

**Intent:** Towers are part of the overall exhibit presentation and, therefore, must be treated as a component of the total exhibit configuration. The maximum height and depth regulations have been set to assure neighboring exhibitors the same reasonable sight line from the aisle as they would expect if they were adjacent to an exhibitor with a standard booth.

## Structural Integrity

All towers in excess of 10' (3.05m) must have drawings available for inspection by exposition management, the installation and dismantling contractor, the exhibitor and governmental authority during the time the tower is being erected, exhibited and dismantled at the show site that include a signature or stamp of a reviewing structural engineer indicating that the structure designed is properly engineered for its proposed use, and a signature of an authorized official of the exhibit building company indicating that the structure is built in compliance with the details and specifications set forth on the drawings.

**Intent:** The structural integrity of towers must be ensured in the overall interests of safety.



## Hanging Signs

An exhibit component suspended above an island exhibit for the purpose of displaying graphics or identification.

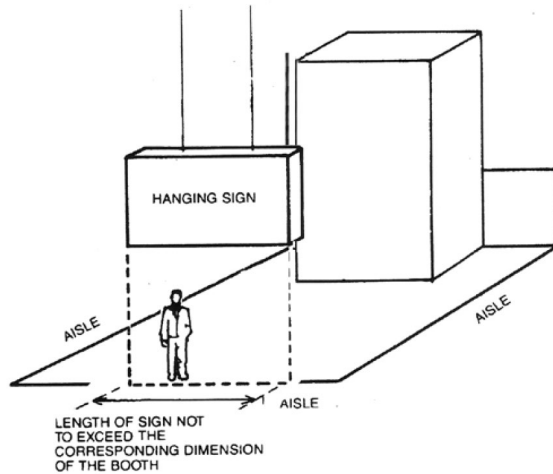

### Height

Hanging identification signs and graphics will be permitted with a maximum height of the given booth's height specifications unless booth is in a convention center low ceiling area in which rigging is prohibited.

**Intent:** Hanging signs are part of the overall exhibit presentation and therefore must be treated as a component of the total exhibit configuration. All signs, whether suspended or attached to the exhibit fixture, will be permitted to a maximum height that corresponds to the appropriate exhibit configuration.

### Size

Hanging signs and graphics will be permitted to a total length on each side of the exhibitor's space, but may not over hang the aisle.

### Structural Integrity

All hanging signs must have drawings available for inspection by exposition management, the installation and dismantling contractor, the exhibitor and governmental authority during the time the component is being hung, suspended and removed at the show site that include a signature or stamp of a reviewing structural engineer indicating that the stress points for hanging the sign have been properly engineered, and a signature of an authorized official of the exhibit building company indicating that the structure is built in compliance with the details and specifications set forth on the drawings.

**NOTE** Exhibitors are encouraged to use lightweight materials in the construction of a hanging sign to eliminate excessive stress to the facility ceiling structure.

**Intent:** The structural integrity of the sign, its means of suspension and anchoring systems must be ensured in the overall interest of safety.

**NOTE:** Any hanging items from the ceiling such as signs and graphics must be pre-approved by Show Management at least 60 days prior to the exposition. Hanging signs are prohibited in low ceiling areas.

## Exhibitor Appointed Contractor Authorization

If your company plans to use a contractor other than an official contractor, please complete the Exhibitor Appointed Contractor Authorization form and **return it by August 23, 2024.**

Failure to do so will result in the inability of the contractor to serve your exhibit. In addition, your selected contractor must furnish an original Certificate of Insurance showing general liability coverage from an insurance company in good standing with minimum policy limits of \$1,000,000 per occurrence and \$2,000,000 aggregate. The insurance must be in force throughout the entirety of the event, including installation and dismantling of Sun Shading Expo North America 2024 and naming Messe Stuttgart Inc. (170 Pine Point Rd., Scarborough, ME 04074 (USA)) as certificate holder. The additional insureds must read as follows: Messe Stuttgart Inc., Anaheim Convention Center and Freeman.

These requirements will be strictly enforced.

**CONVENTION CENTER RULES** - It is each exhibitor's responsibility to ensure they and their EAC are in compliance with convention center rules and regulations.

<https://visitanaheim.mediaalet.com/portals/ACC-Rates-Policies-Guidelines>